



JOINING
INNOVATION
AND EXPERTISE

ACCURATe project

Vicki James

Introduction

Aerospace
Composite
Components
Ultrasonic
Robot
Assisted
Testing

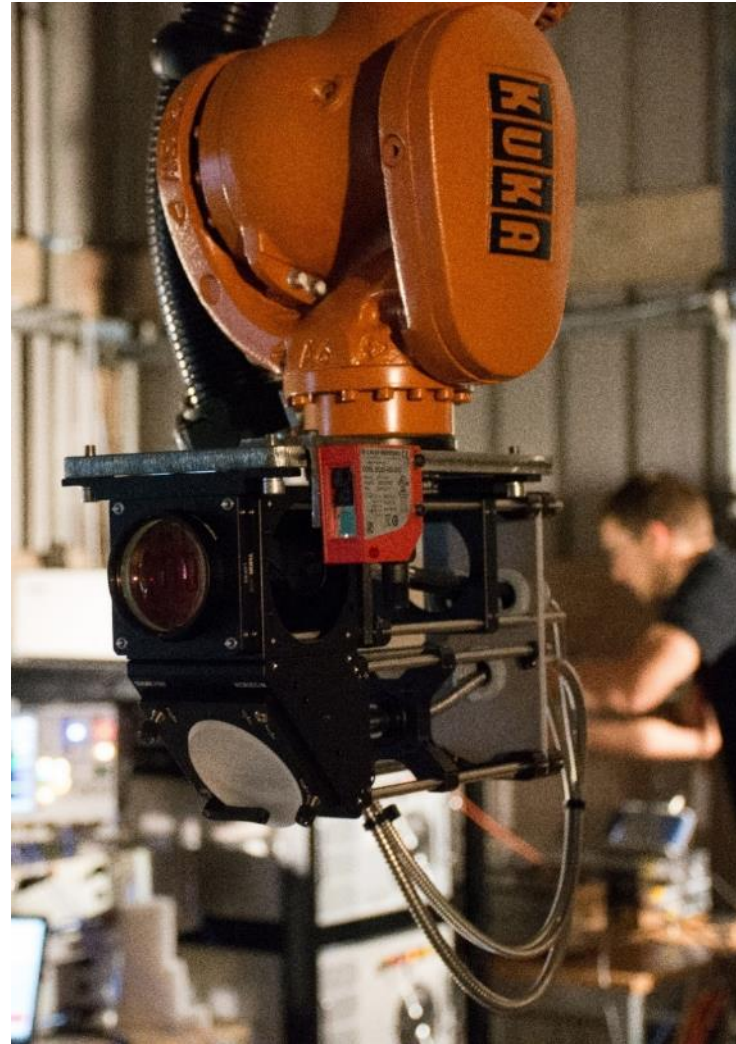

Project Work Packages

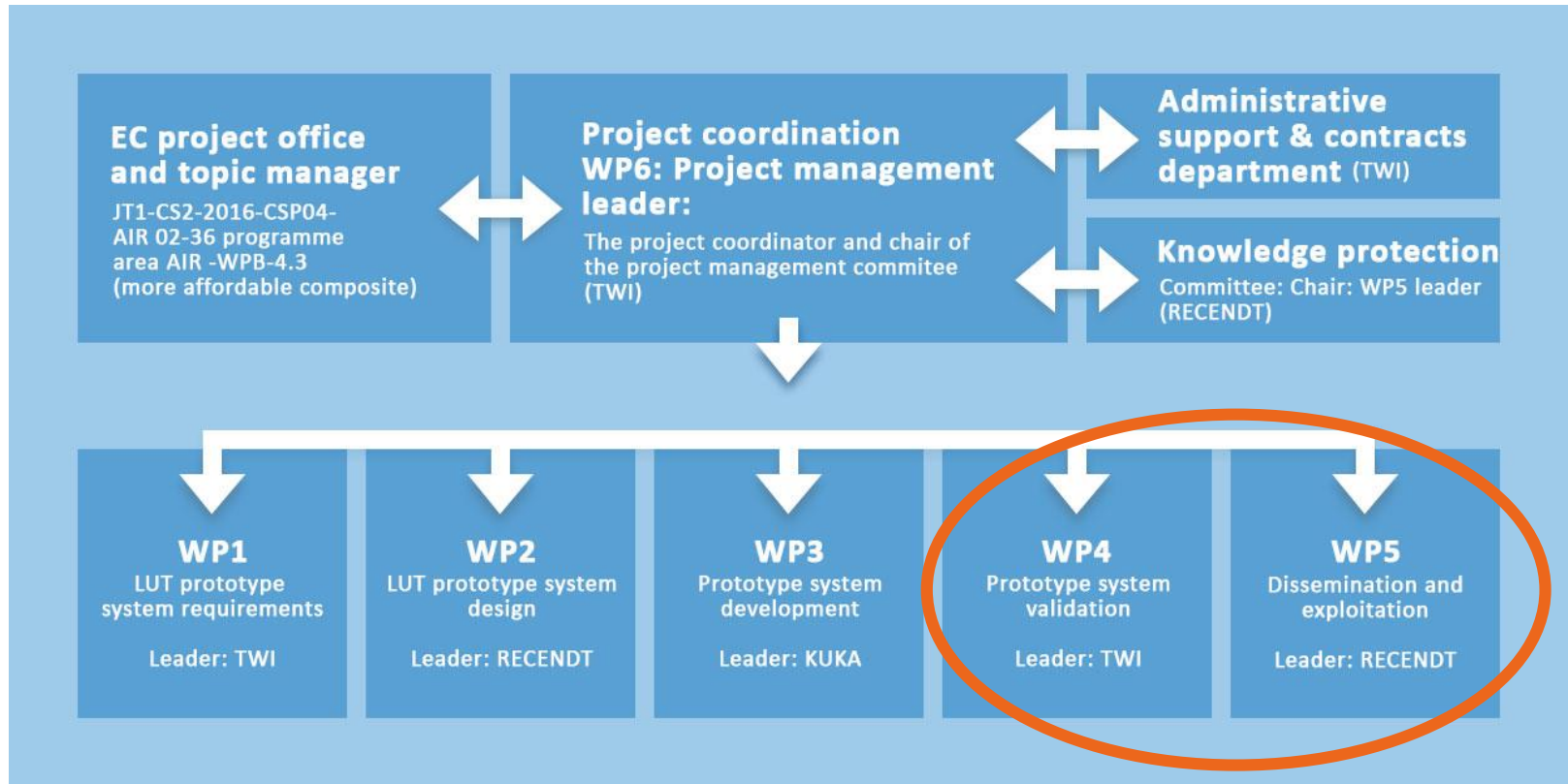

Current Work Packages

The ACCURATe Project - Background

- Part of Clean Sky 2 framework
- Specifically “More Affordable Composite Fuselage”
- EU’s Horizon 2020 research and innovation programme
- c. €2M grant funding received
- 44 month project
- Project commenced June 2017



The ACCURATe Project - Overview

- Composites are key to reducing fuel costs and emissions
- State of the art aircraft contain up to 80% by weight of composites in their load bearing structures
- Two key barriers to overcome:
 - (i) High cost of manufacture
 - (ii) Increased risks of both internal defects and impact damage leading to structural failure
- Hence the requirement for more efficient, effective and comprehensive inspection processes and systems

The history of LUT in Aerospace



Why Laser ultrasonic testing?

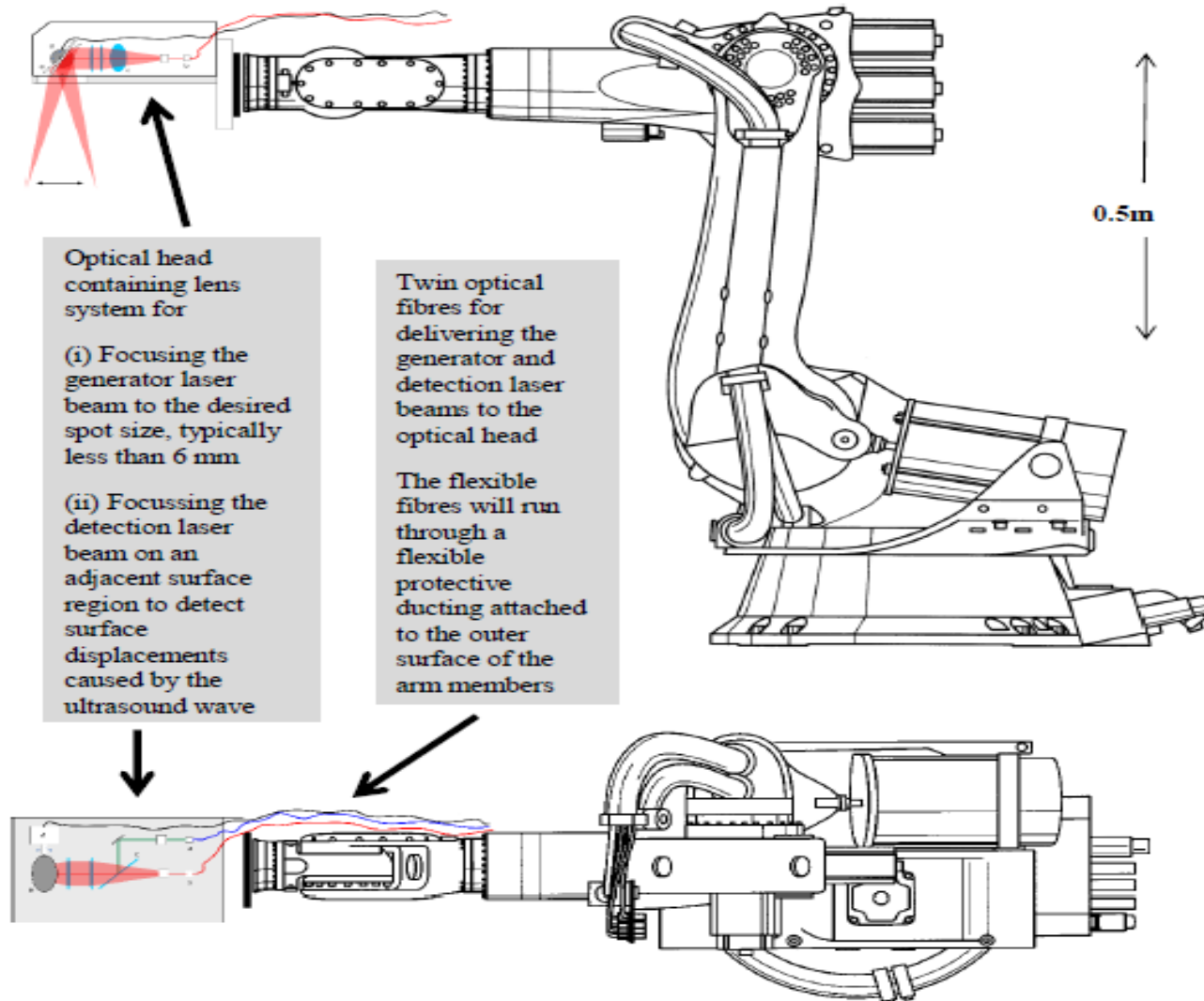

Project Partners

Topic Manager

LEONARDO AIRCRAFT

KUKA



ACCURATe Consortium

Laser Ultrasonic testing-LUT

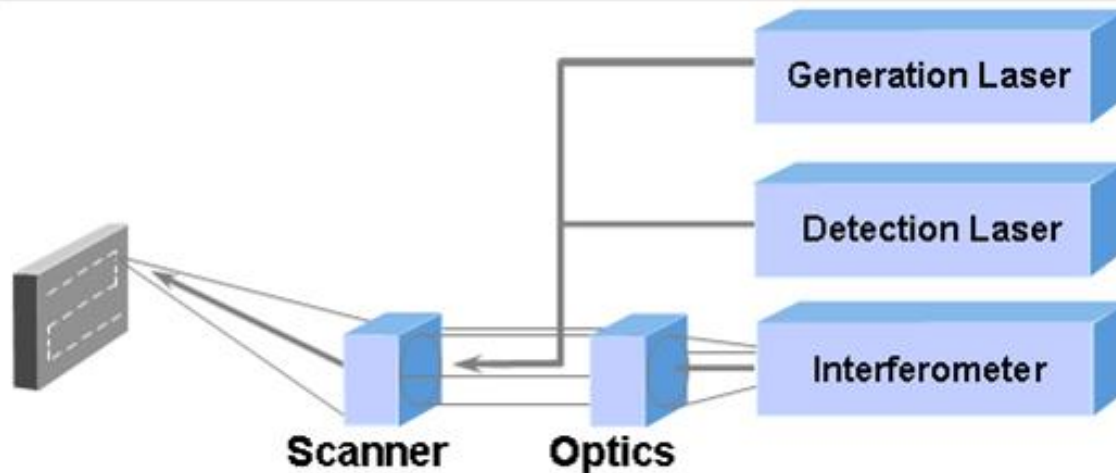
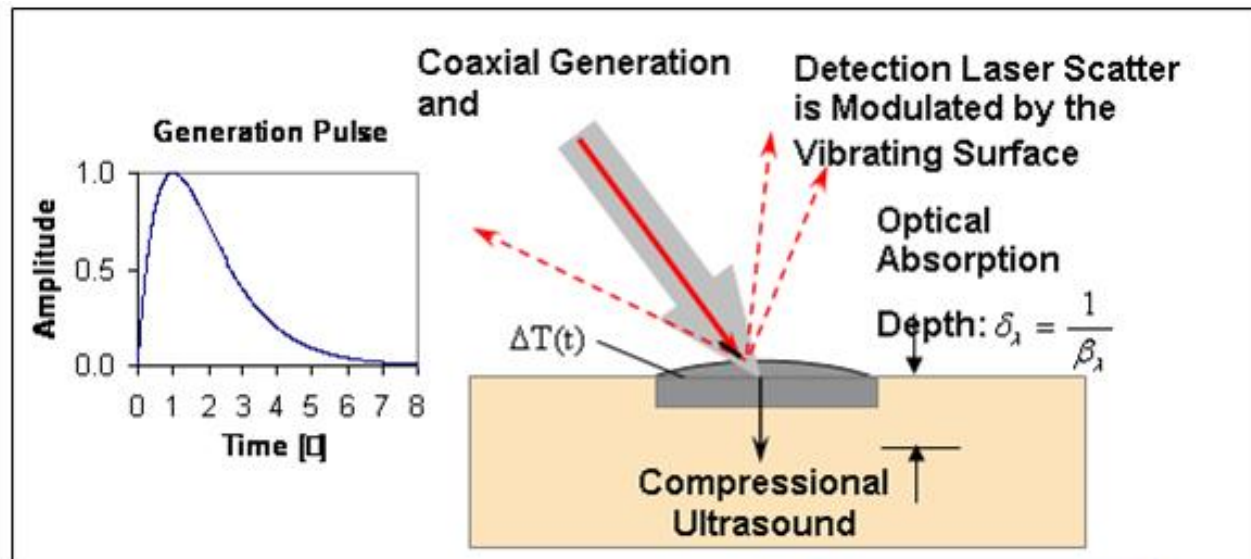

The challenges of LUT

Defect detection in highly dampening materials and therefore requiring the detection of weak signals (caused by highly ultrasonic dampening materials) the project has aimed to create innovations to improve the Signal to noise ratio:



Austrian nationally funded project: K-Project ZPT+, courtesy by RECENDT GmbH.

Advantages of Laser UT

- High speed inspection process
- Lightweight scanning head with small footprint
- Broadband UT frequency generation
- Low maintenance
- High accuracy
- Non contact
- No couplant
- Offline path planning and simulation for efficient working



Project Aims

- Develop a prototype laser ultrasonic testing (LUT) system for non-destructive inspection (NDI) of :
 - Large scale aircraft hybrid and thick composite structures
 - Structures containing acoustic damping materials
 - Materials which highly attenuate ultrasound

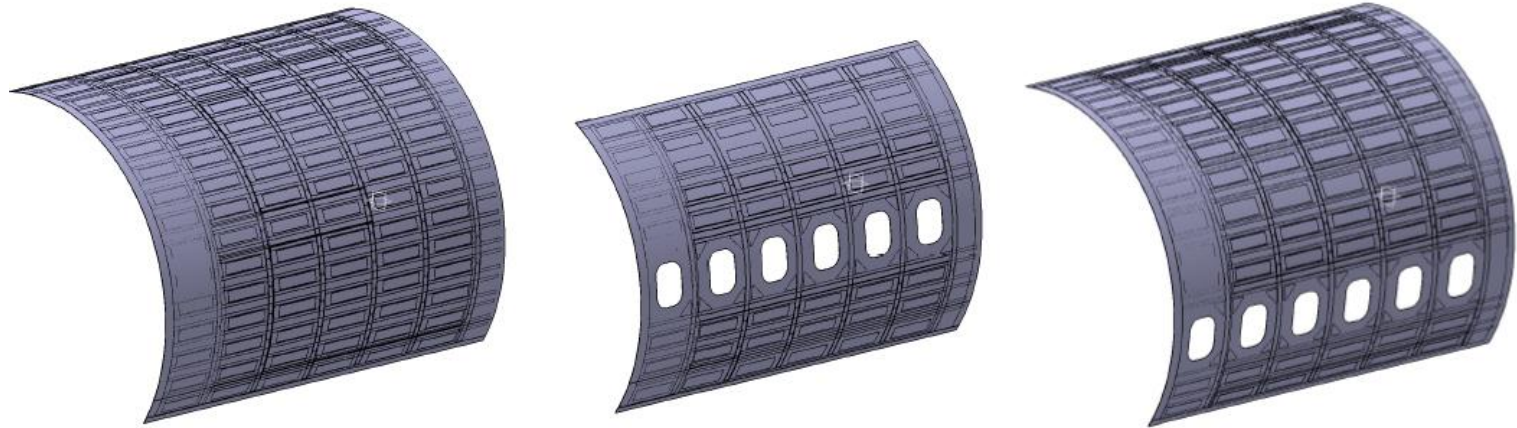

Challenges of the project

- Laser & robot safety
- Inspection speed critical
- Laser power optimisation
- System vibration & noise
- Multiple systems integration
- Physical space constraints and robot reach



System Overview

- 6-axis robot mounted on linear track
- Fibre coupled, pulsed generation and detection lasers
- Interferometer and signal processing unit
- Fully integrated software for laser & robot control, data acquisition and data analysis
- Two position superpanel mounting fixture

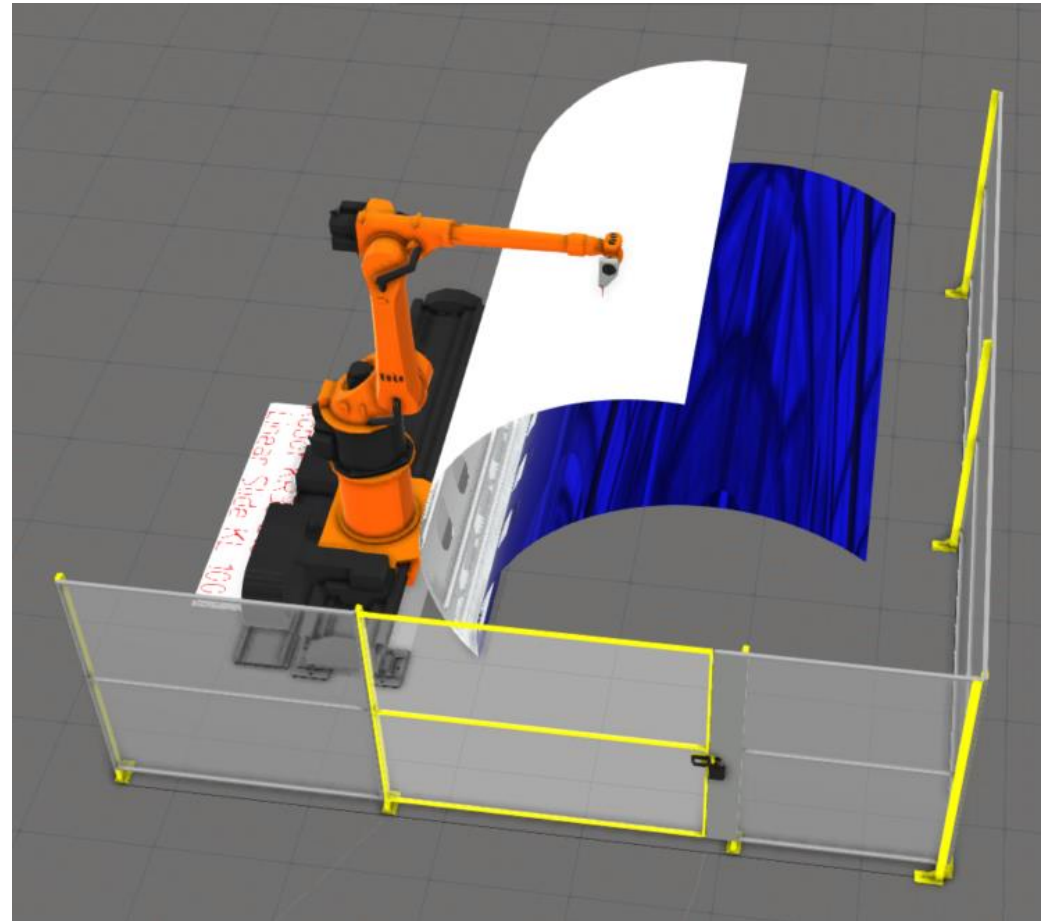

Specification and performance*

- Inspection cell size (m): 8 x 7 x 5 (W x D x H)
- Inspection material types: Hybrid composite laminates
- Largest component: c. 17m²
- Maximum component thickness: 30ply + additional layers
- Inspection rate: >8m²/h
- Minimum detectable defect size: 6mm square
- Robot positional accuracy: ±0.7mm
- Robot pose repeatability: ±0.1mm
- Minimum robot step size: 0.1mm
- Scanning index: 0.5 - 3 mm (0.5 mm increments)

* Design parameters

Robotic system

- KR30-L16 robot manipulator
- KL1000 Linear Track with 2700mm travel
- KRC4 Robot Controller
- 5200mm wide loading doors & cell access doors
- Integrated Fortress Interlock door locking / access system

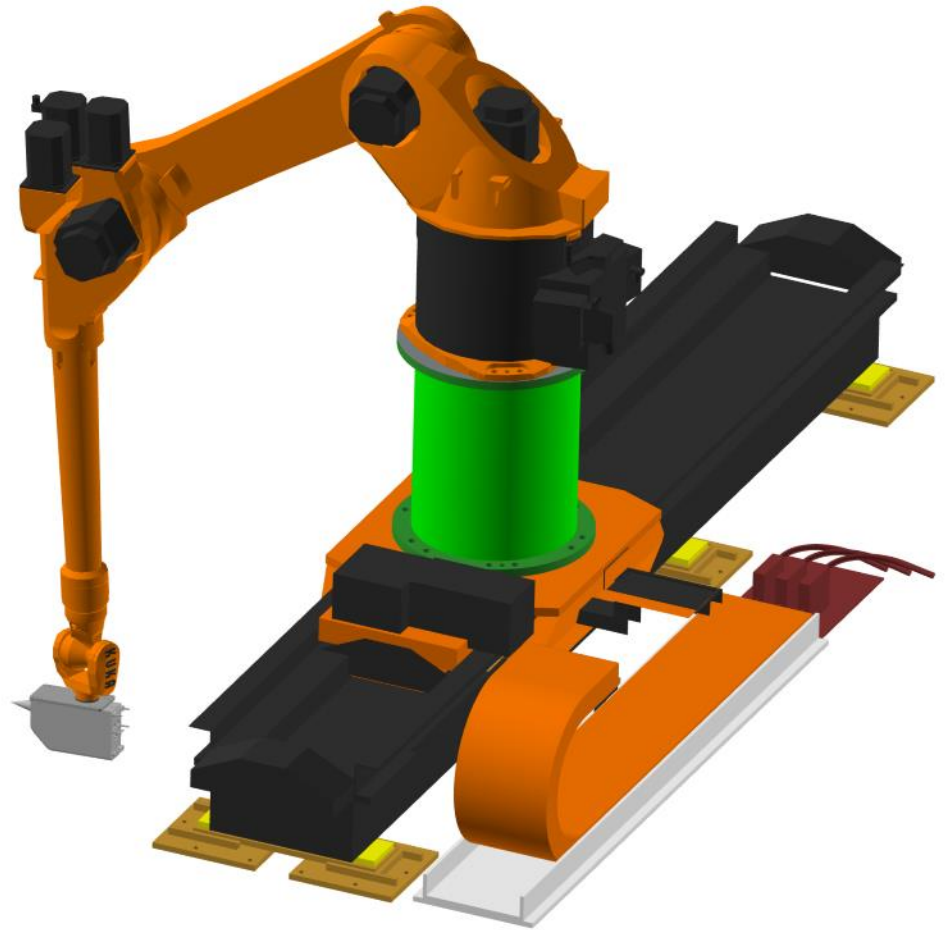

Laser Systems

Generation Laser:

Type: diode pumped solid state laser

Wavelength: 532 nm

Pulse length: 10 ns

Pulse repetition rate: 400 Hz

Beam diameter: 4 mm

Pulse energy 30 mJ (at fibre output)

Detection Laser:

Type: diode pumped continuous wave /
Nd:YAG laser

Wavelength: 1064 nm

Pulse repetition rate: 400 Hz

Pulse length: 50 μ s

Pulse energy 29mJ (at fibre output)



Optical Systems

- Passive optical laser head
- Fibre coupled to stationery two wave mixing (TWM) interferometer unit
- Back scattered light from sample surface converted to amplitude changes
- Amplitude changes measured by photodetectors (photodiodes)

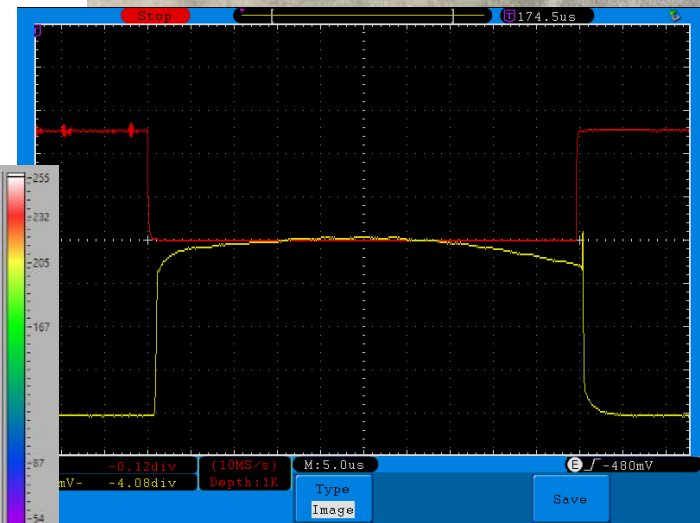
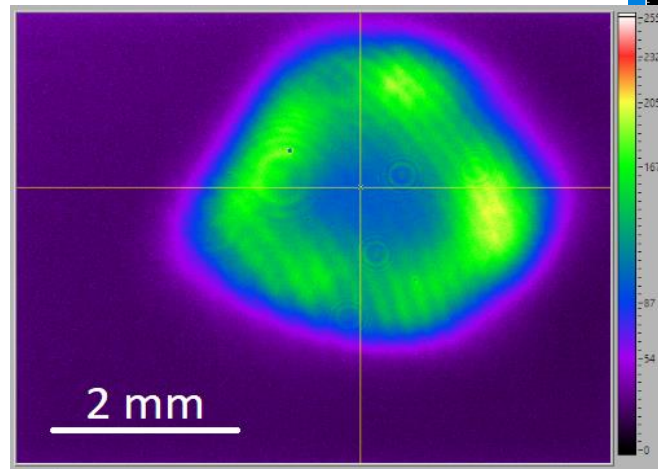
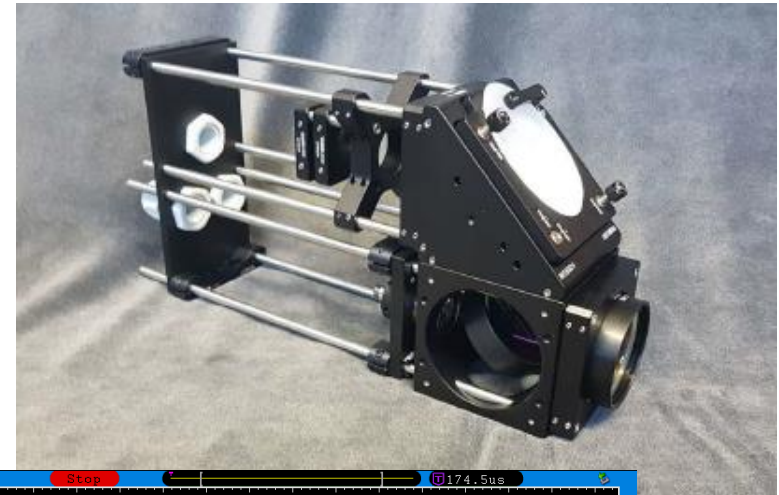

Software

- Bespoke software for data acquisition, analysis and visualisation of inspection results
- Display and analyse data in A-scan, B-Scan and 3D view
- Offline data processing & visualisation
- Full interaction with the 3D model
- Indication logging and reporting

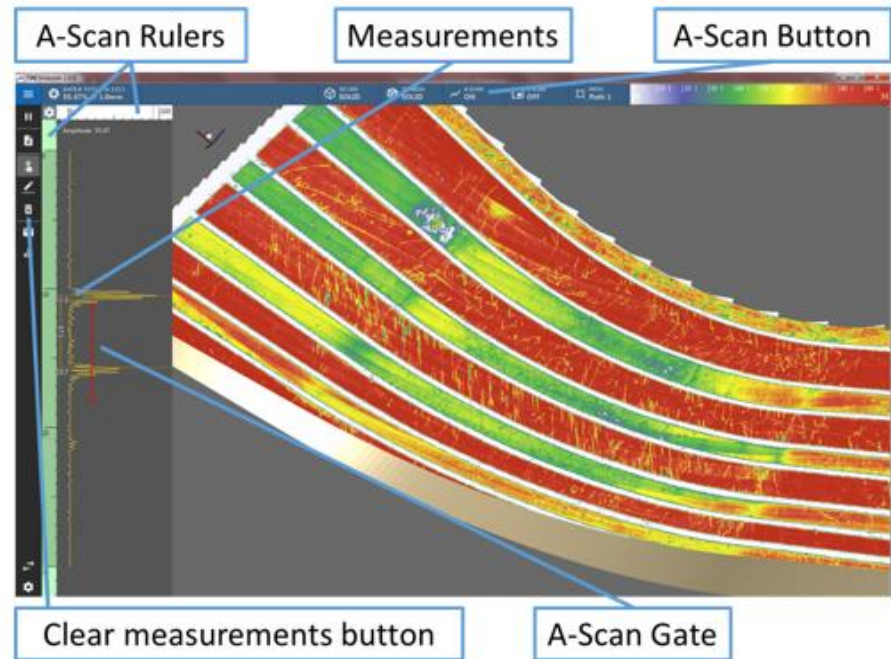

Software functions

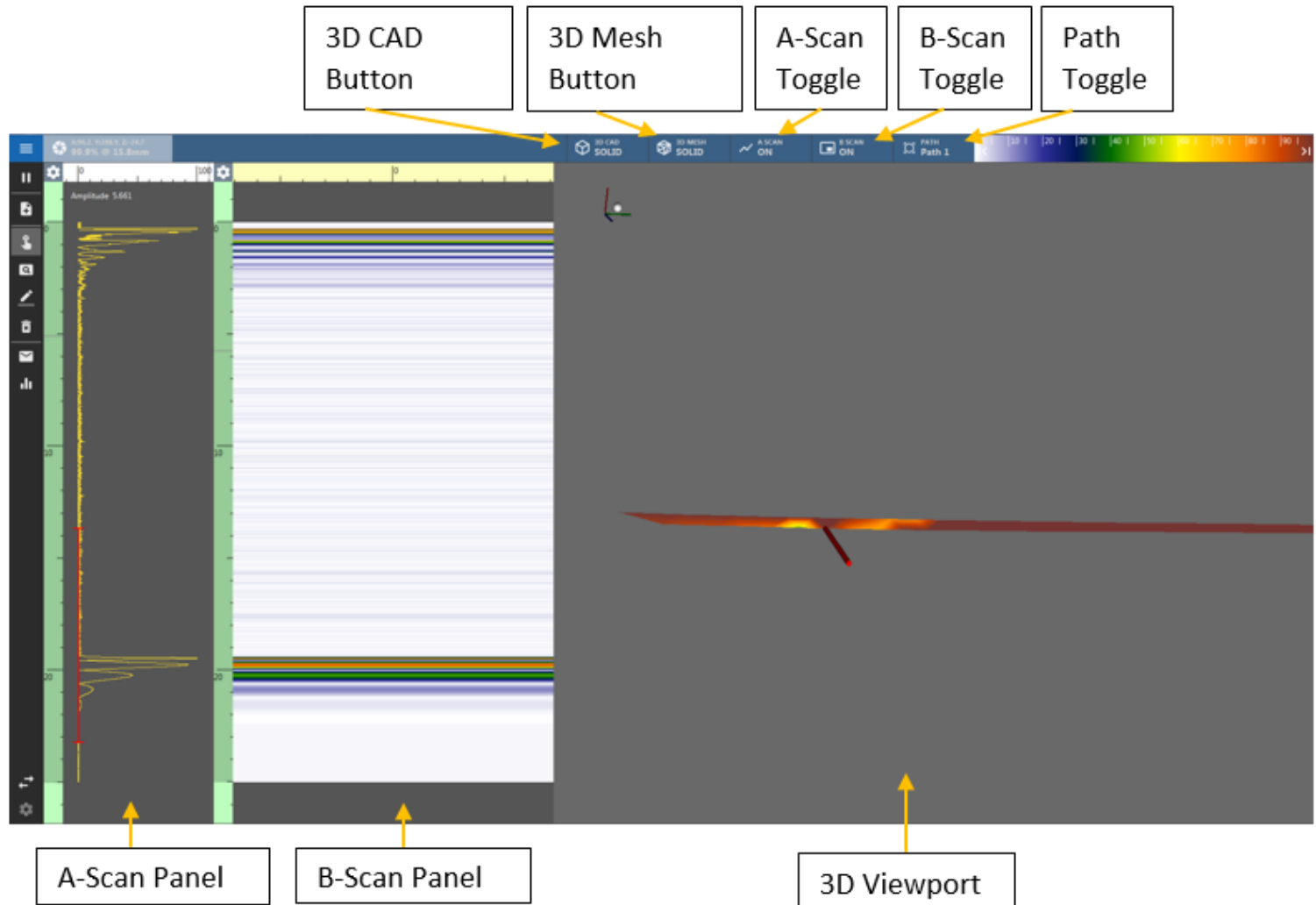

A scan features

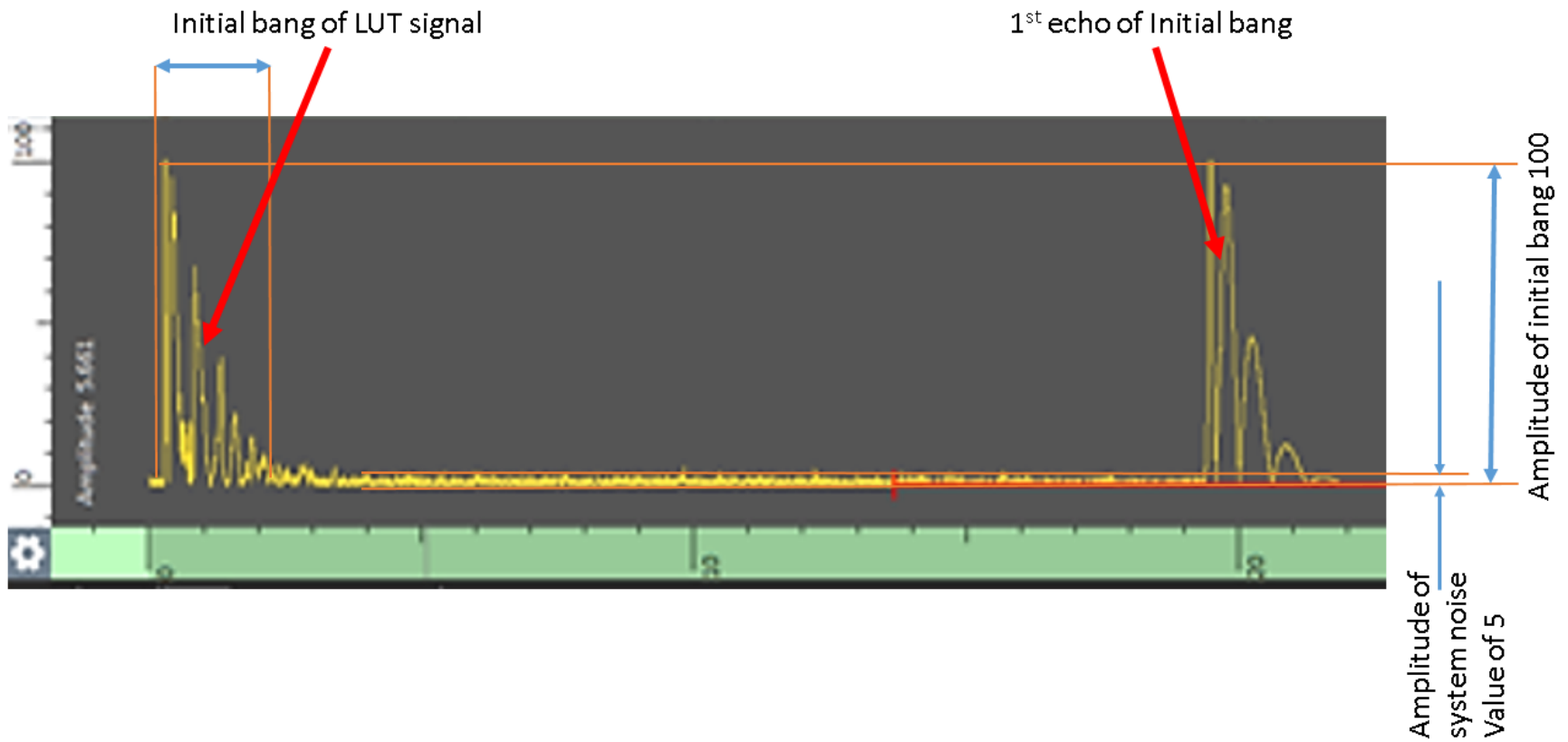

Measurement of flaws

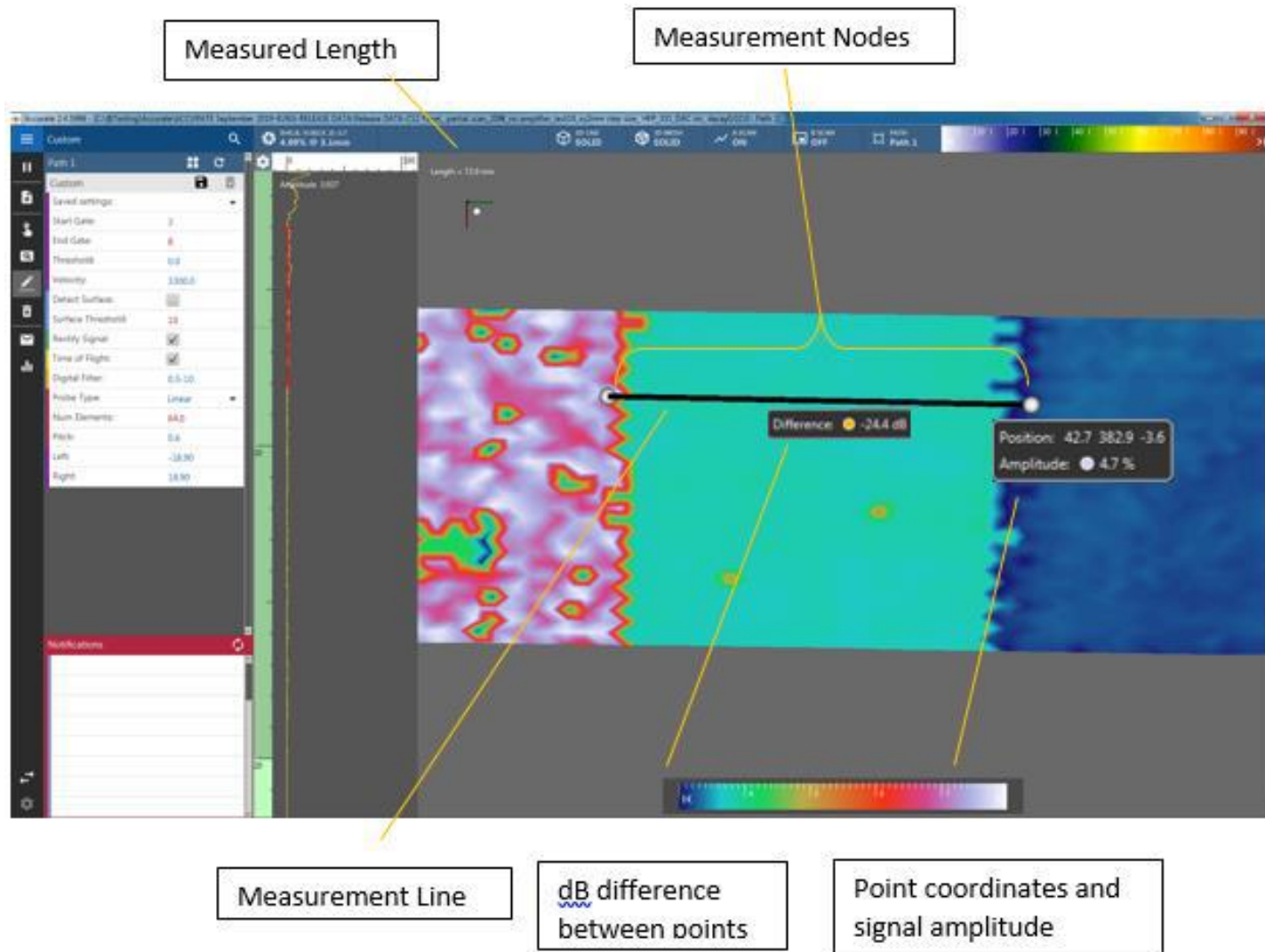

Offline Path Planning & Simulation

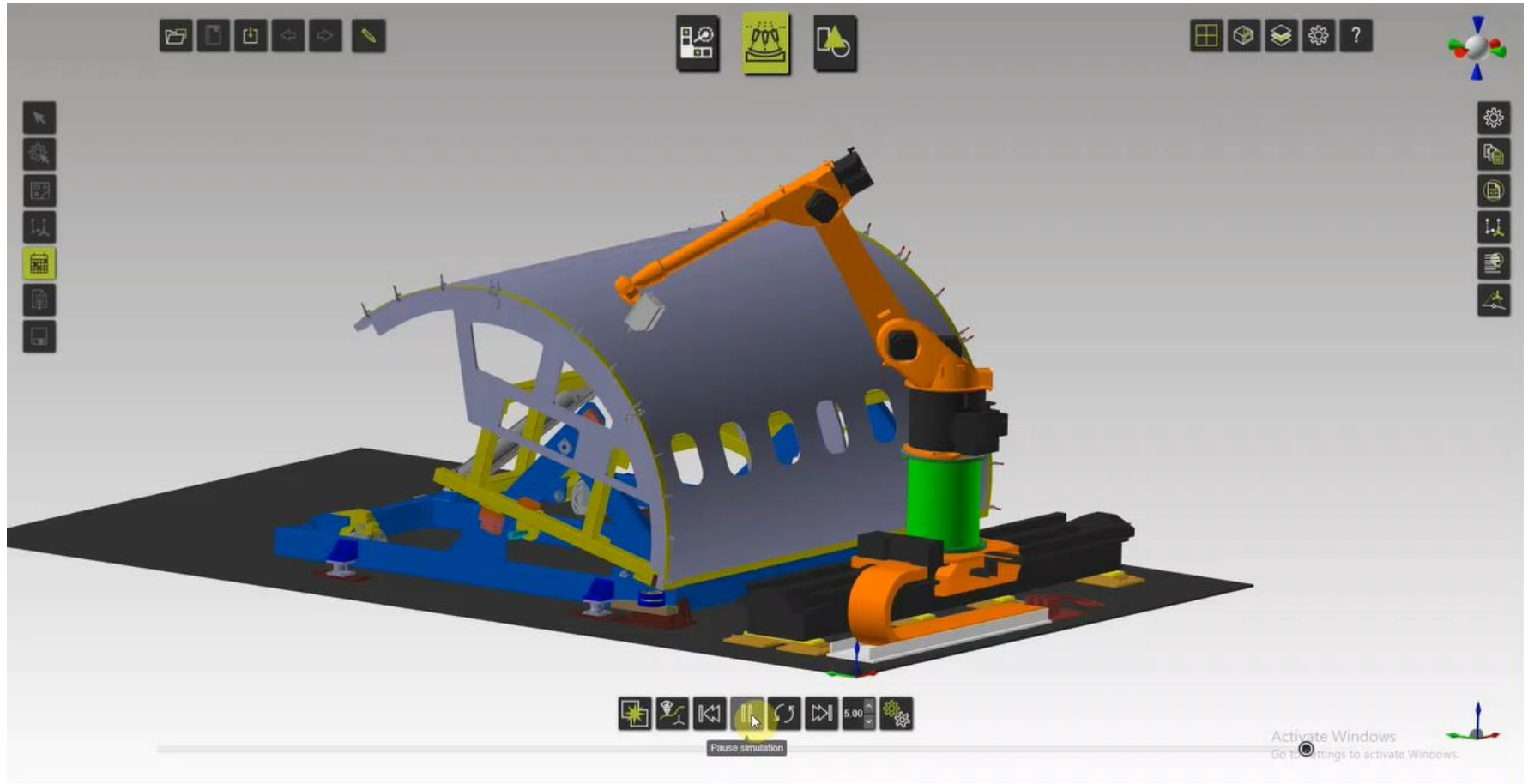

Superpanel Fixture design

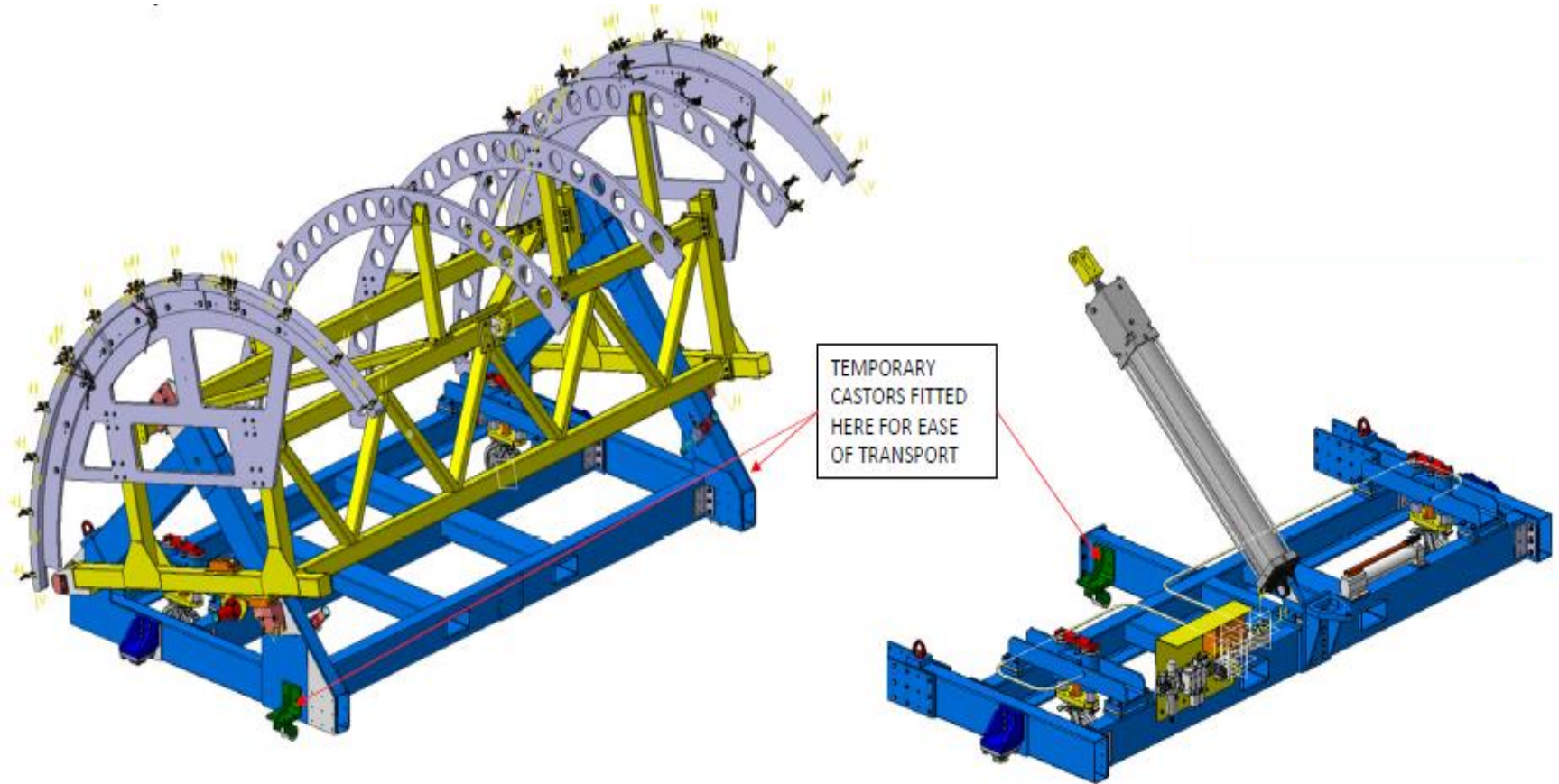

Initial Testing of the LUT system

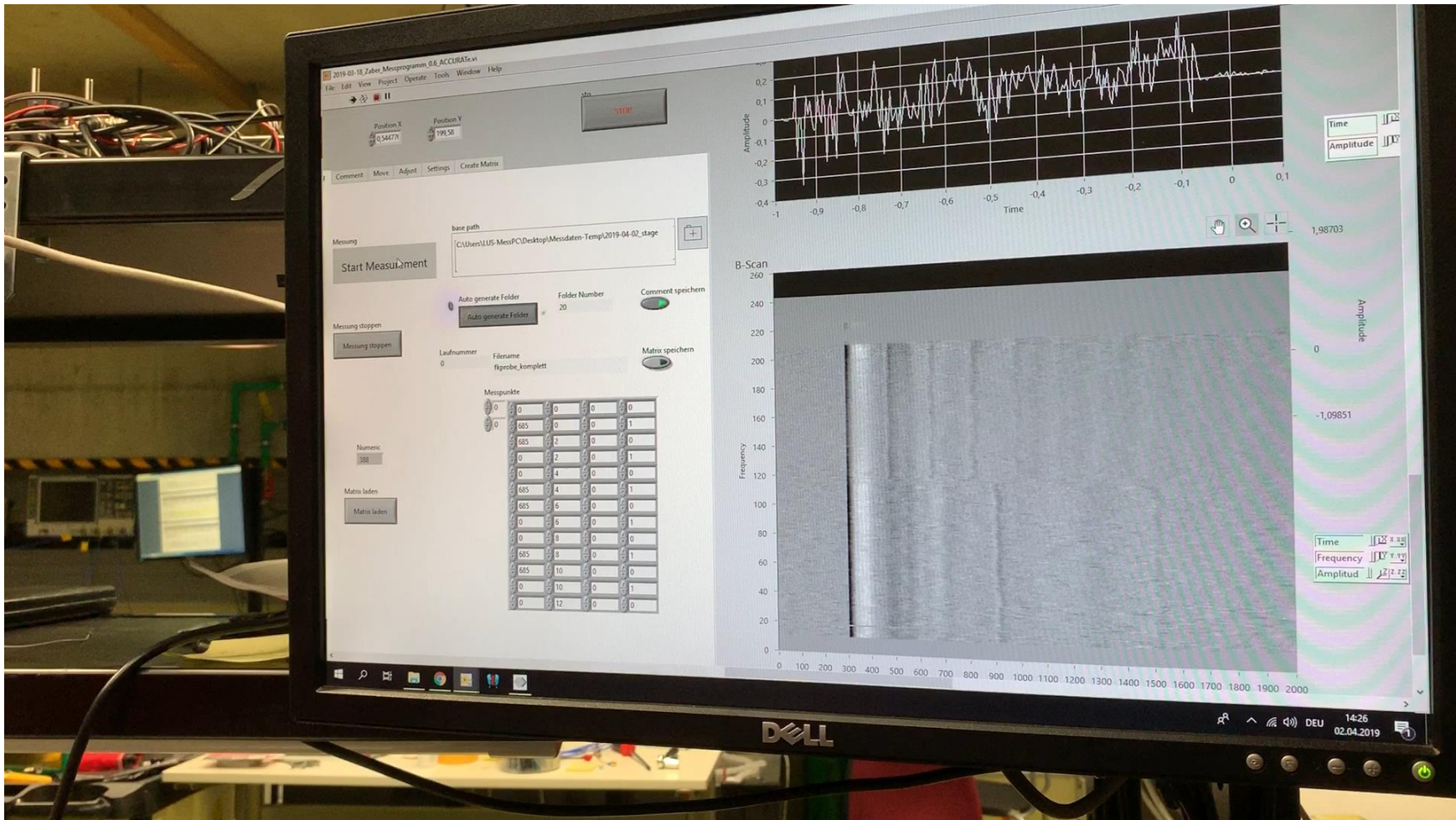

The CS2 reference panel

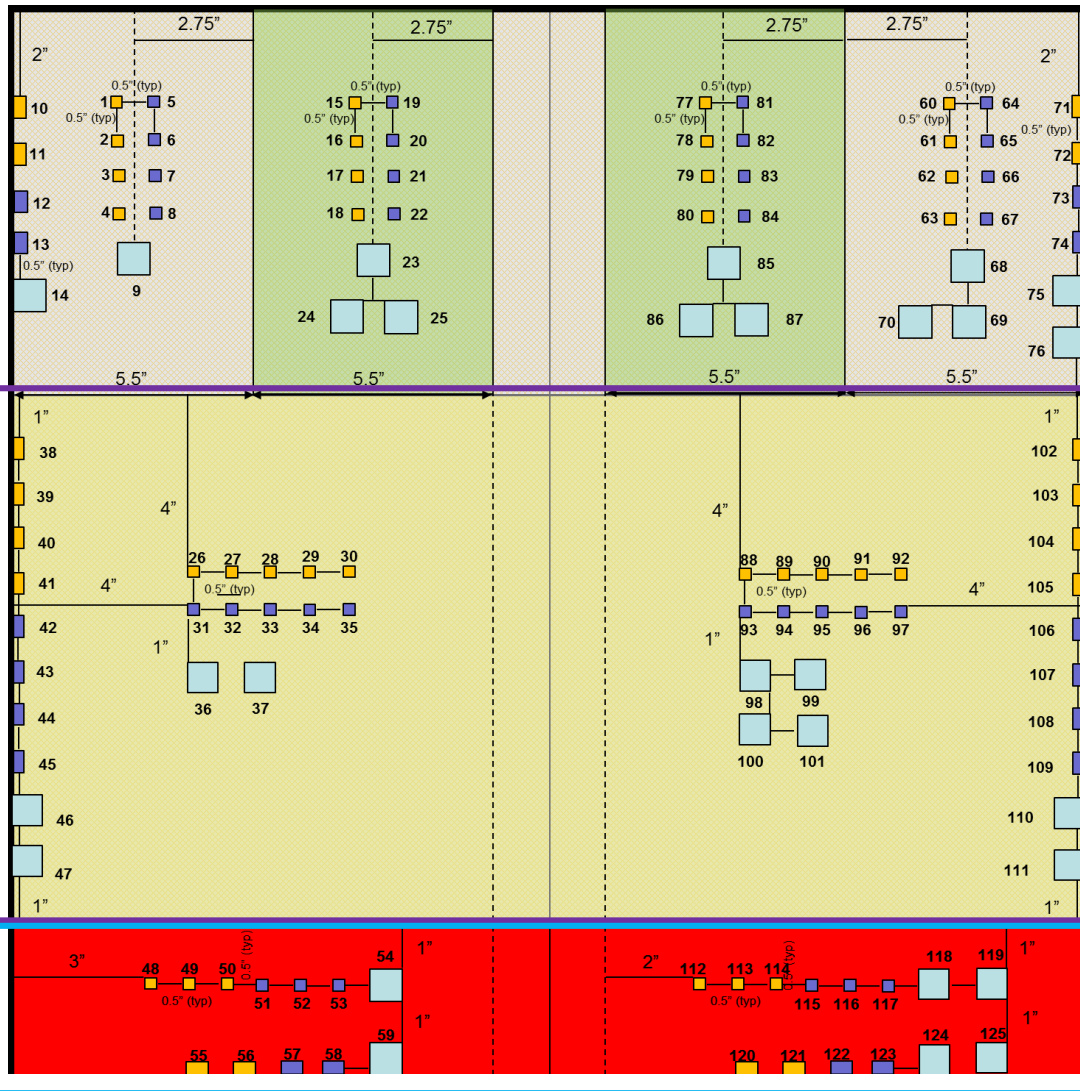

The CS2 reference panel contains

- Artificial flaws 6 x 6mm
- Artificial flaws 17 x 17mm
- Visco-elastic layers
- 8 ply and 30 ply sections
- Fiberglass sections
- Copper mesh sections

Viscoelastic region

Black paint region

System Testing

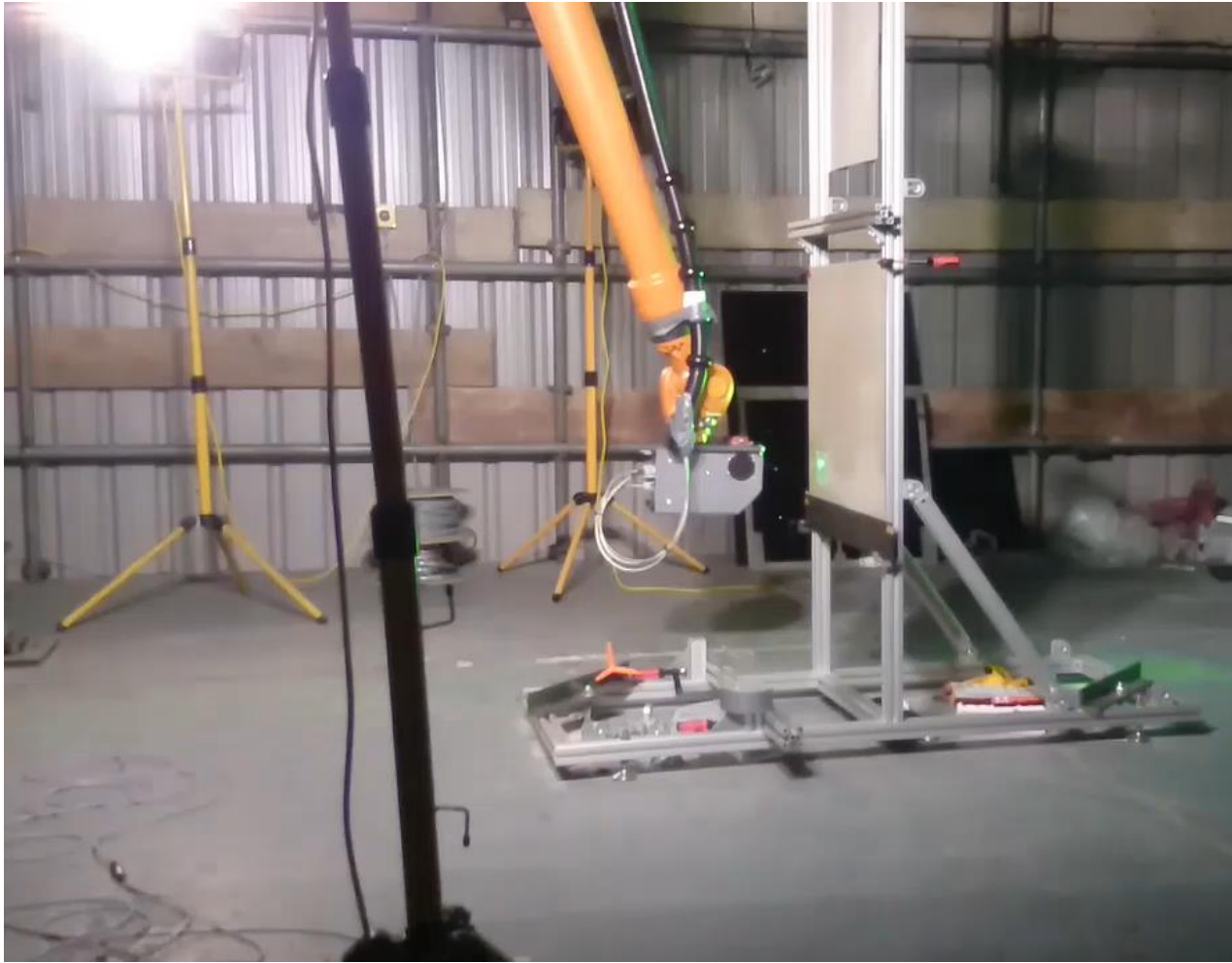

LUT results

GATE

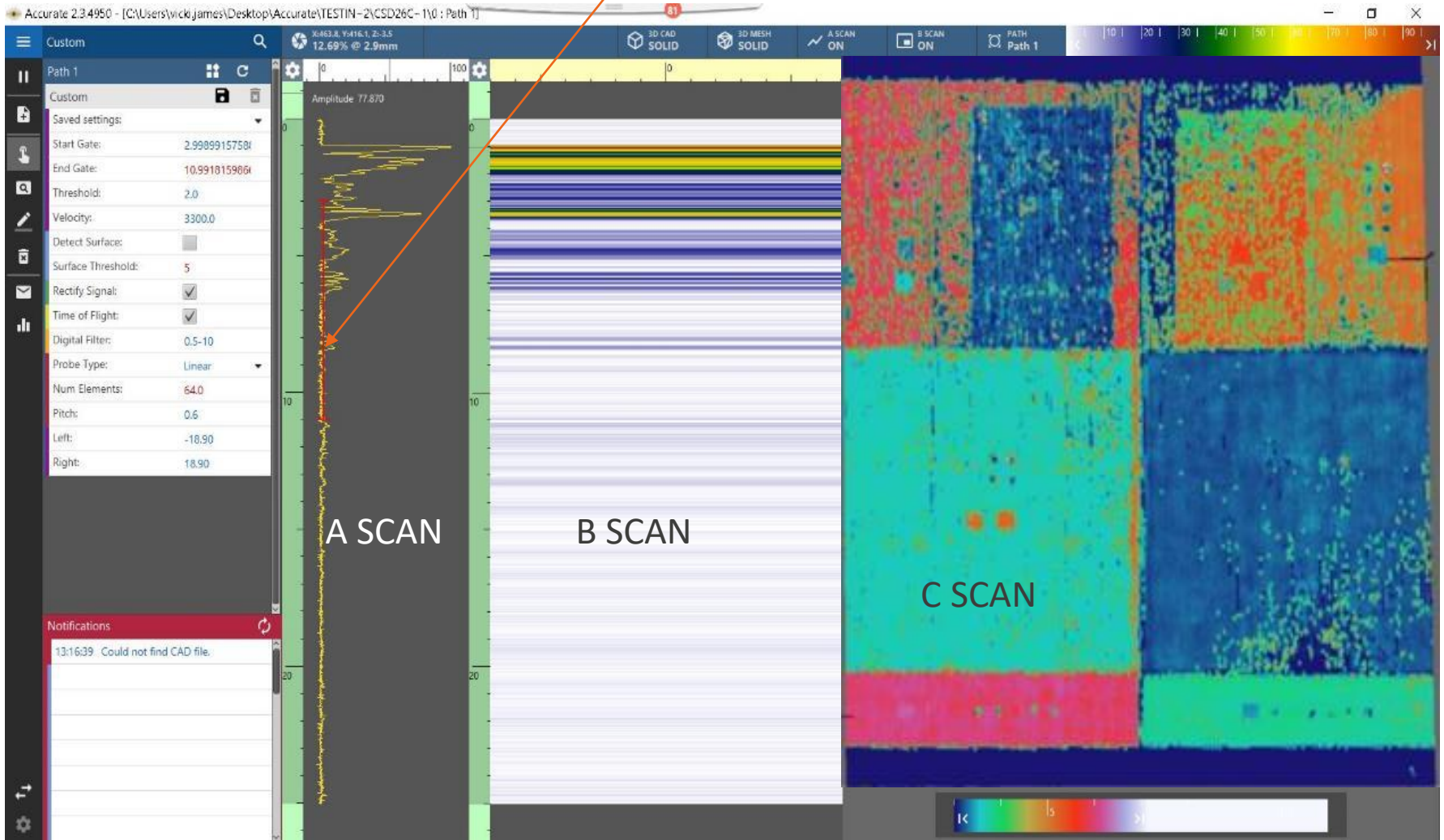

Colour coding of artificial flaws

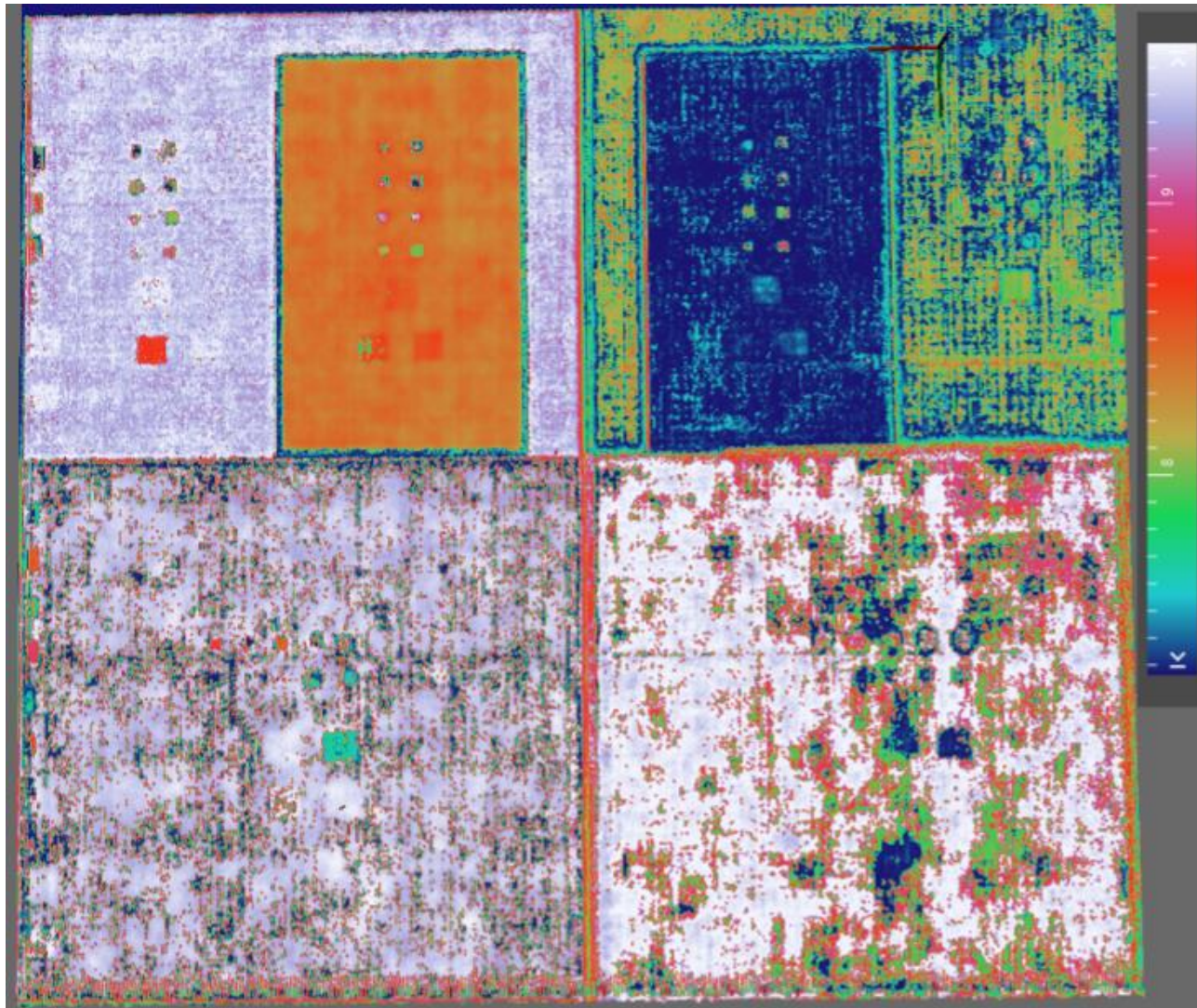

Flaw detection by viewing B scan-cross section

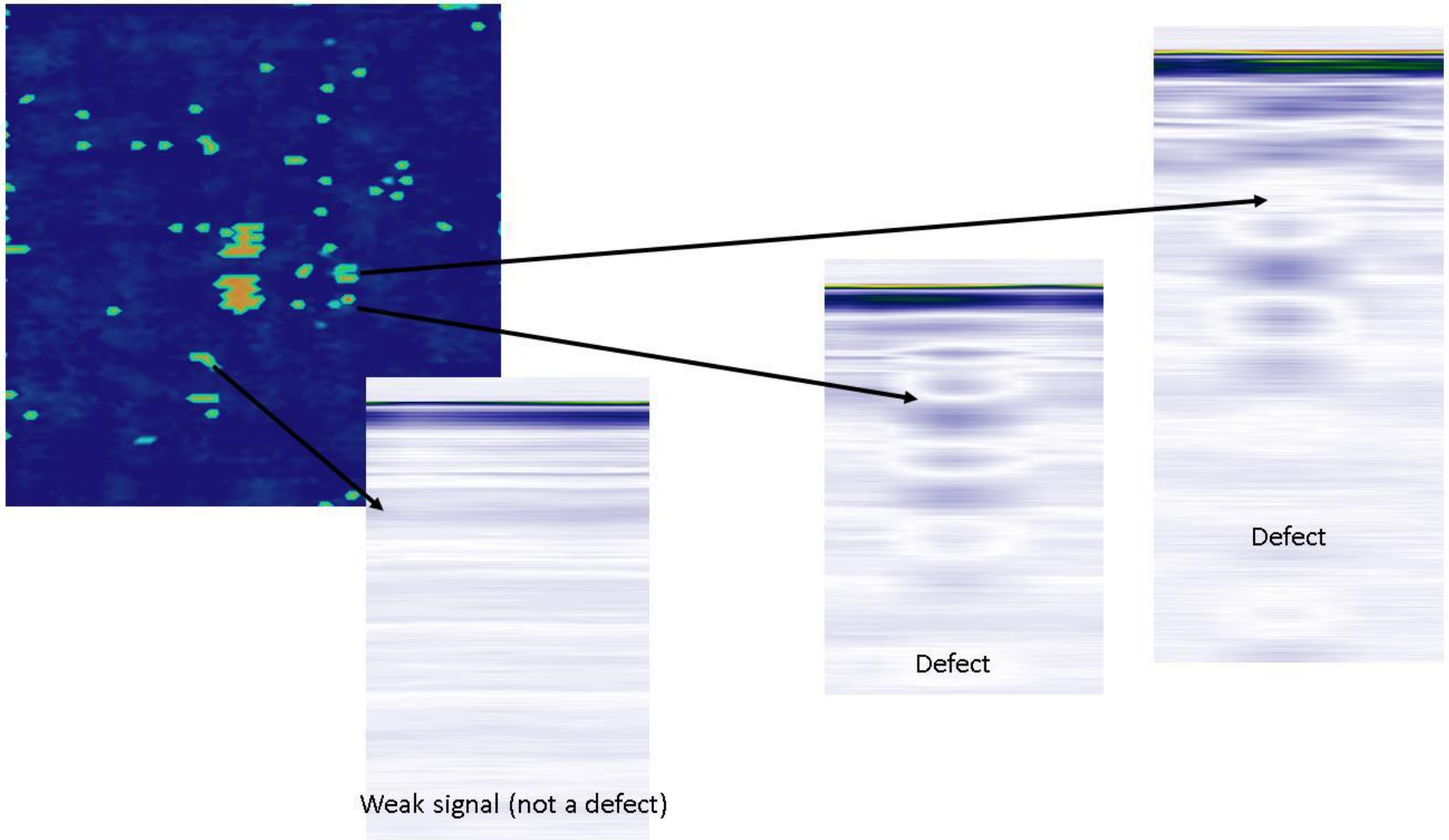

Histogram function

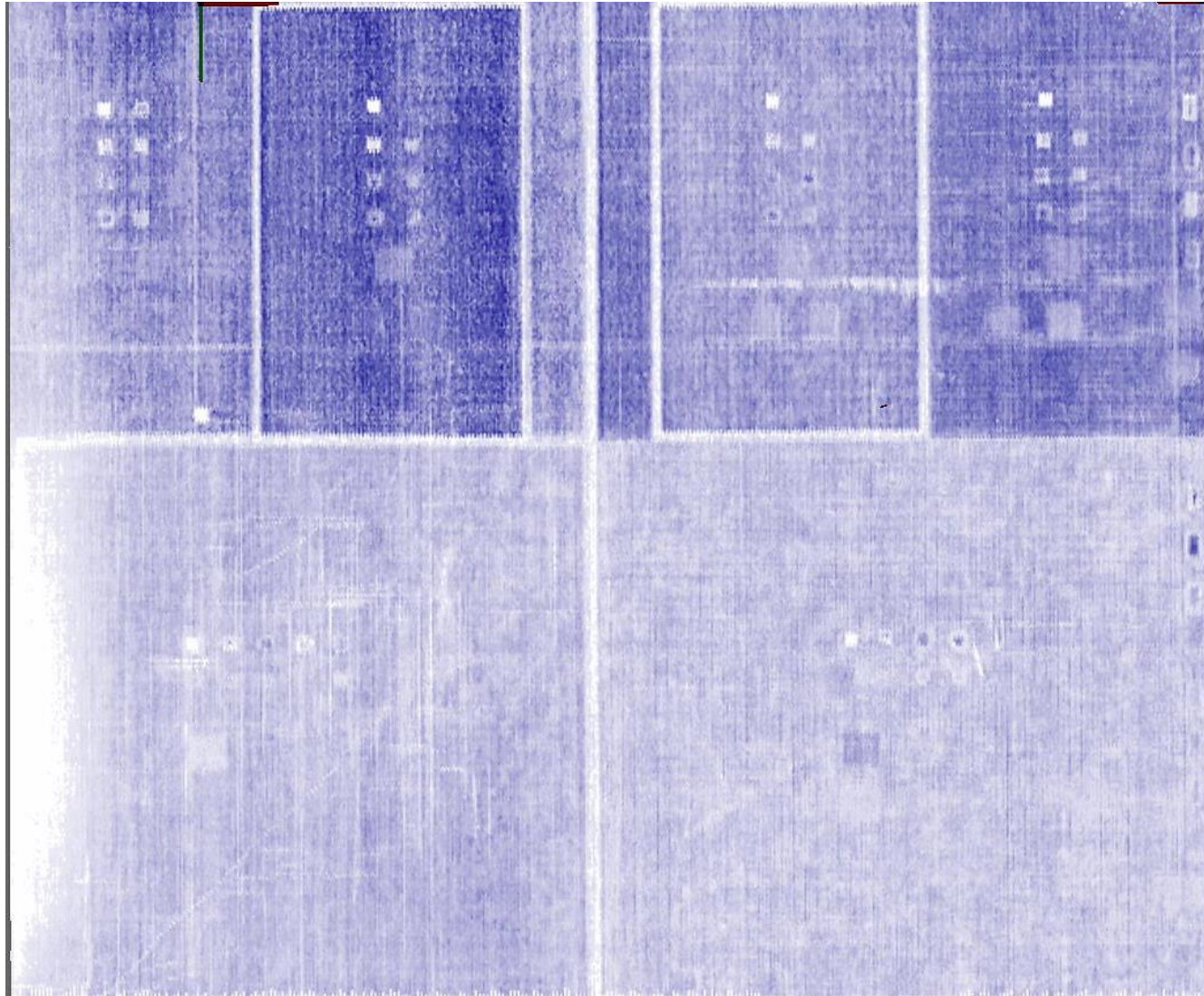

System Testing-Scrap fuselage panel



System Testing



Rear views of the panel showing stringers and ribs

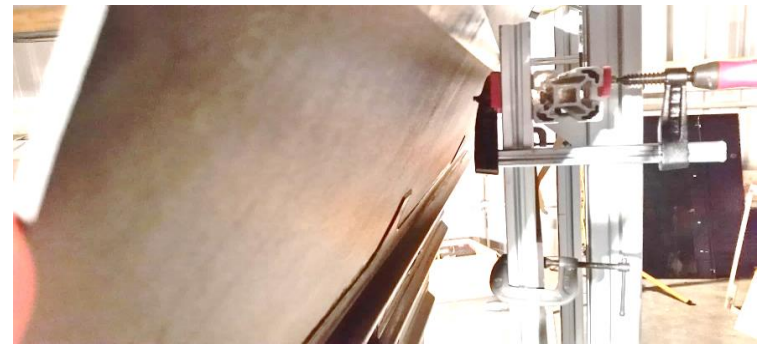

LUT results

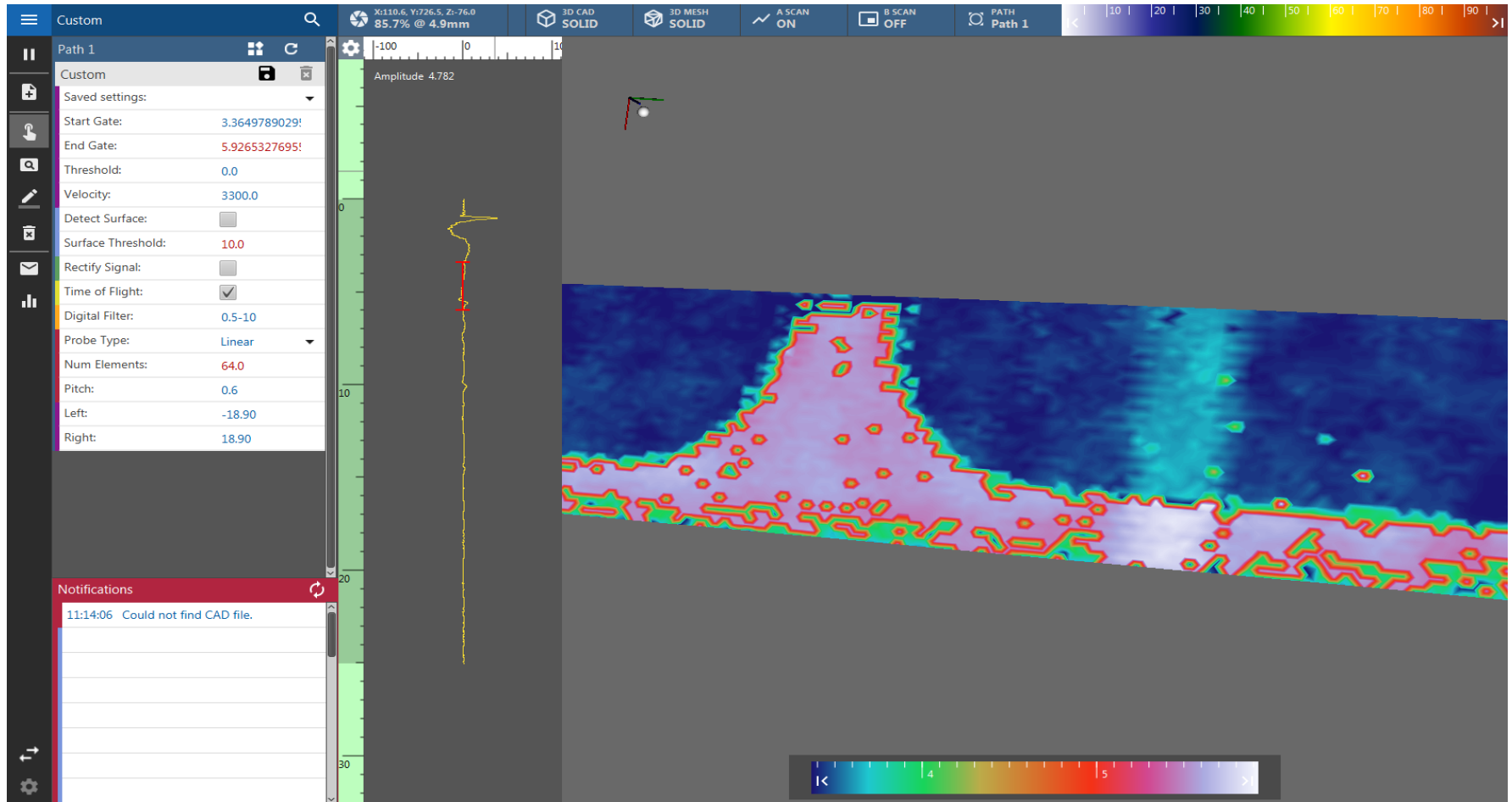

Scrap fuselage panel detailed results

Left Hand Side of panel

Right Hand Side of panel



Left Hand Side of panel

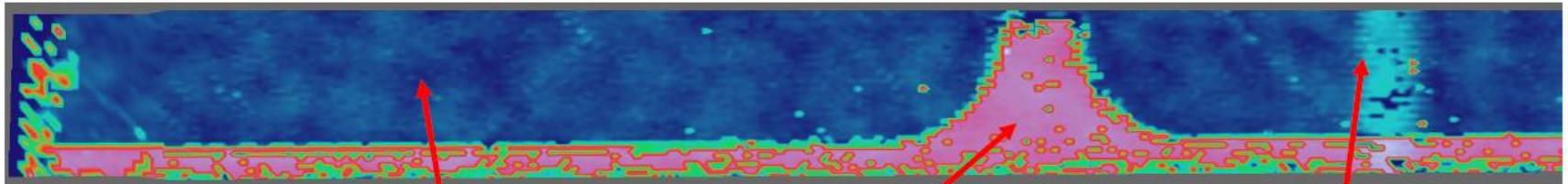

Single layer material

Stringer area

Additional support material

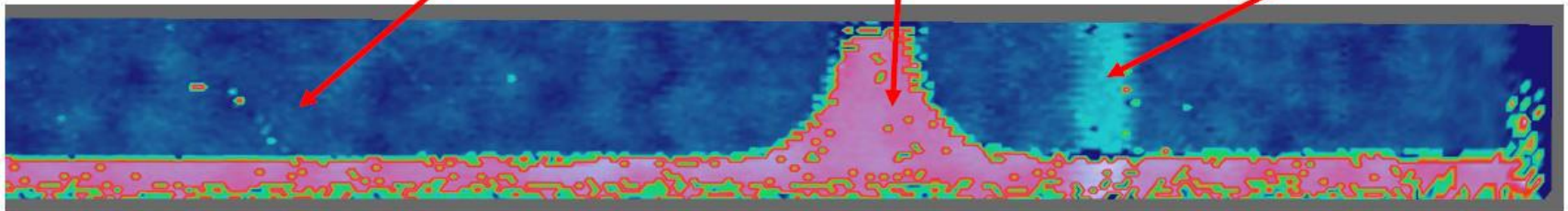

Right Hand Side of panel

Programme & Progress

Current status:

- Prototype LUT system commissioned
- LUT data acquisition and analysis software passed initial testing
- Proof of concept
- Completed integrated system tests

Next steps:

- Improvement of Signal to Noise ratio via electronic amplification
- Installation at Topic Manager site
- System validation trials & performance tests
- CE Marking
- Completion – Q1 2021

Questions ?

www.accurate-project.eu

The logo for ACCURATe, featuring the word in a bold, blue, sans-serif font with a white starburst effect behind the letter 'A'. The logo is set against a dark blue rectangular background.

ACCURATe

Thank you for listening

vicki.james@twi.co.uk

+44 (0)1639 873100

+44 (0)7843 688102